

## Operating manual

Humidity and temperature transmitters / Hygrostats

### HVAC40... series



Members of GHM GROUP:

**GREISINGER**

**HONSBERG**

**Martens**

**DeltaOHM**

**VAL.CO**

[www.deltaohm.com](http://www.deltaohm.com)

Keep for future reference.

# TABLE OF CONTENTS

<b>1</b>	<b>INTRODUCTION .....</b>	<b>3</b>
<b>2</b>	<b>TECHNICAL CHARACTERISTICS .....</b>	<b>4</b>
<b>3</b>	<b>INSTALLATION .....</b>	<b>7</b>
3.1	ELECTRICAL CONNECTIONS .....	9
3.2	CONFIGURATION DIP SWITCHES IN THE MODELS WITH ANALOG OUTPUT.....	10
3.3	CONFIGURATION DIP SWITCHES IN THE MODELS WITH RS485 DIGITAL OUTPUT.....	11
3.4	CONFIGURATION DIP SWITCHES IN THE MODELS WITH RELAY OUTPUT .....	11
3.5	CONFIGURATION VIA THE SERIAL PORT.....	12
3.6	CONFIGURATION VIA THE INTERNAL BUTTONS (ONLY HVAC40R17...) .....	16
<b>4</b>	<b>ALARM OPERATING MODES (HVAC40R17...).....</b>	<b>18</b>
<b>5</b>	<b>MODBUS-RTU (HVAC40S17...) .....</b>	<b>20</b>
<b>6</b>	<b>INSTRUMENT STORAGE .....</b>	<b>21</b>
<b>7</b>	<b>SAFETY INSTRUCTIONS.....</b>	<b>21</b>
<b>8</b>	<b>ACCESSORIES ORDERING CODES .....</b>	<b>22</b>

# 1 INTRODUCTION

**HVAC40...** series transmitters and hygrometers measure temperature, relative humidity and dew point using an **interchangeable** relative humidity and temperature digital sensor.

A stainless steel 10 µm filter protects the sensor against dust and particles (other filters are available for different applications).

The probe is available in three different versions:

- fixed vertical probe for wall mounting (HVAC40...**TV**);
- fixed probe with 2 m cable (HVAC40...**TC.2**);
- fixed duct horizontal probe (HVAC40...**TO**).

Available outputs, depending on the model:

- RS485 Modbus-RTU digital output (HVAC40**S**17...);
- 0...10 V voltage analog output (HVAC40**V**17...);
- 0...20 mA / 4...20 mA active current analog output (HVAC4017...);
- 2-wire (current loop) 4...20 mA analog output (HVAC40**A**17...);
- ON/OFF relay switch (HVAC40**R**17...).

Versions with 4-digit LCD display (option L) are available, which allow the measured parameters to be displayed.

In the versions with LCD, two LED indicators indicate the presence of the power supply and of an eventual alarm condition: exceeding of the set measurements thresholds, in the versions with relay switch output; measurement detected outside the measuring range, in the versions with analog or digital output.

The instruments are factory calibrated and ready for use.

The configuration can be made by connecting the serial port of the instrument to the PC or by means of the quick configuration dip switches on the circuit board. The versions with relay switch output are equipped with two internal buttons for the configuration via display.

## Models

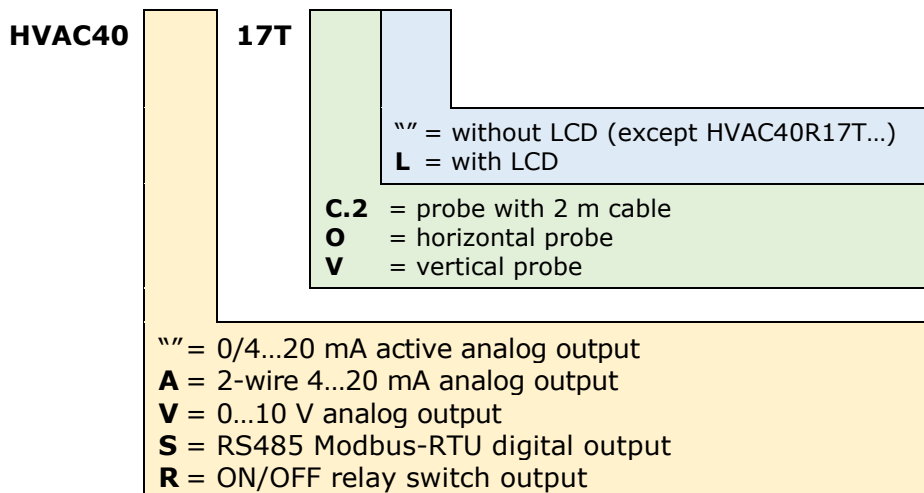

## 2 TECHNICAL CHARACTERISTICS

<b>Sensor</b>	<b>Interchangeable</b> digital relative humidity and temperature sensor
<b>Measuring range</b>	0...100 %RH / recommended 5...80 %RH -20...+80 °C / -20...+80 °C Td
<b>Resolution</b>	0.1 %RH / 0.1 °C / 0.1 °C Td
<b>Accuracy</b>	Typ. $\pm 2.5$ %RH (5...80 %RH) @ $t = 15...35$ °C Typ. $\pm 0.3$ °C @ $t = -20...70$ °C / $\pm 0.5$ °C @ $t =$ remaining range For the Dew Point see the table below
<b>Long term drift</b>	Typ. $< 0.25$ %RH/year Max. $0.03$ °C/year
<b>Response time</b>	10 s (63% of final value with 1 m/s air flow)
<b>Output</b>	<ul style="list-style-type: none"> <li>• HVAC4017...: Active analog 0...20 or 4...20 mA (<math>R_{Lmax} = 500 \Omega</math>)</li> <li>• HVAC40V17...: Analog 0...10 Vdc (<math>R_{Lmin} = 10 k\Omega</math>)</li> <li>• HVAC40A17...: 2-wire (current loop) 4...20 mA (<math>R_{Lmax} = (Vdc-12)/0,022</math>)</li> <li>• HVAC40S17...: Digital RS485 Modbus-RTU</li> <li>• HVAC40R17...: ON/OFF relay switch with SPDT contact 3 A/250 Vac, 3 A/30 Vdc resistive load</li> </ul> <p>The analog output goes to 22 mA or 11 V in case of measurement outside the measuring range.</p>
<b>Alarm</b>	Front red LED: exceeding of the set measurements thresholds in HVAC40R17... models, measurement detected outside the measuring range in the other models. Internal buzzer in HVAC40R17... models.
<b>Power supply</b>	<ul style="list-style-type: none"> <li>• HVAC4017... and HVAC40V17...: 24 Vac <math>\pm 10\%</math> or 18...40 Vdc</li> <li>• HVAC40A17...: 15...30 Vdc</li> <li>• HVAC40S17...: 12...30 Vdc</li> <li>• HVAC40R17...: 24 Vac <math>\pm 10\%</math> or 15...36 Vdc</li> </ul>
<b>Power consumption</b>	<ul style="list-style-type: none"> <li>• HVAC4017...: 20 mA @ 24 Vdc and <math>I_{out}=12</math> mA</li> <li>• HVAC40V17...: 4 mA @ 24 Vdc</li> <li>• HVAC40S17...: 2 mA @ 24 Vdc</li> <li>• HVAC40R17...: <math>&lt; 1</math> W @ 24 Vdc</li> </ul>
<b>Electrical connections</b>	Screw terminal block, max 1.5 mm <sup>2</sup> , PG9 cable gland
<b>Connection to PC</b>	RS232 serial port (except HVAC40S17...) RS485 serial port (only HVAC40S17...) Can be connected to a USB port by using the optional CP27 (except HVAC40S17...) or RS48 (only HVAC40S17...) adapter
<b>Sensor operating conditions</b>	-20...+80 °C. The sensor shows best performance when operated in 20...80 %RH humidity range. Long term exposure outside the indicated range (especially at high humidity) may temporarily offset the sensor response. The sensor is protected from water and dust.
<b>Instrument operating conditions</b>	-20...+60 °C / 0...95 %RH
<b>Storage temperature</b>	-20...+80 °C
<b>Housing dimensions</b>	80 x 84 x 44 mm
<b>Protection degree</b>	IP65

**Accuracy of Dew Point measurement** (parameter calculated from the measurement of relative humidity and temperature):

		DP °C														
		-20	-10	0	10	20	30	40	60	80						
Temperature °C	-20	≤±1	<b>DP LIMIT</b>													
	-10	≤±1									≤±1					
	0	≤±1									≤±1	≤±1				
	10	≤±3									≤±1	≤±1	≤±1			
	20	≤±4									≤±2	≤±1	≤±1	≤±1		
	30	<b>NOT SPECIFIED</b>									≤±3	≤±1.5	≤±1	≤±1	≤±1	
	40										≤±2	≤±1	≤±1	≤±1		
	60	<b>NOT SPECIFIED</b>									≤±5	≤±2.5	≤±2	≤±1	≤±1	
	80										≤±4	≤±2	≤±1	≤±1		

For example, at 20 °C environmental temperature, the Dew Point value of 0 °C is measured with an accuracy better than 1 °C.

**DIMENSIONS (mm)**

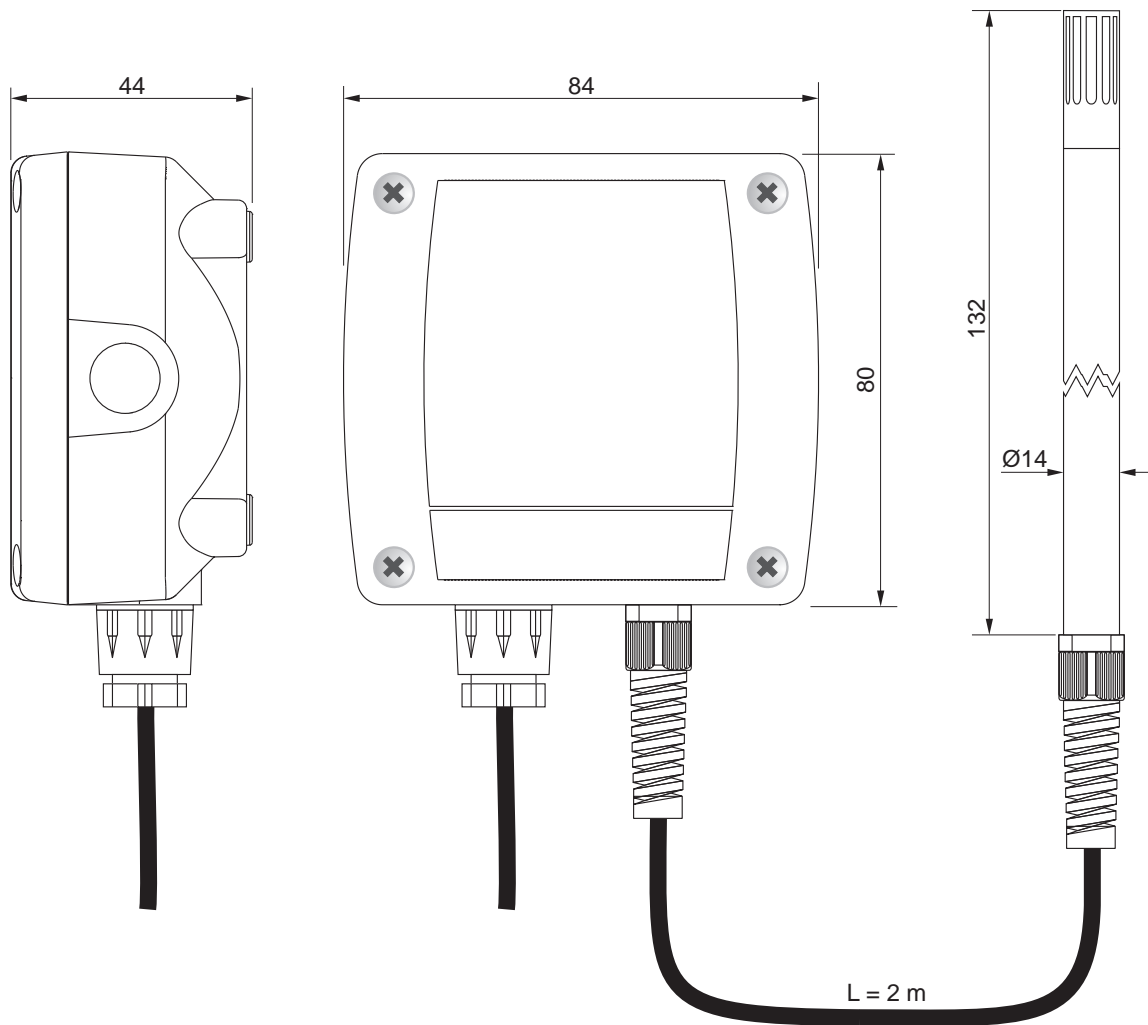

**HVAC40...17TC.2**

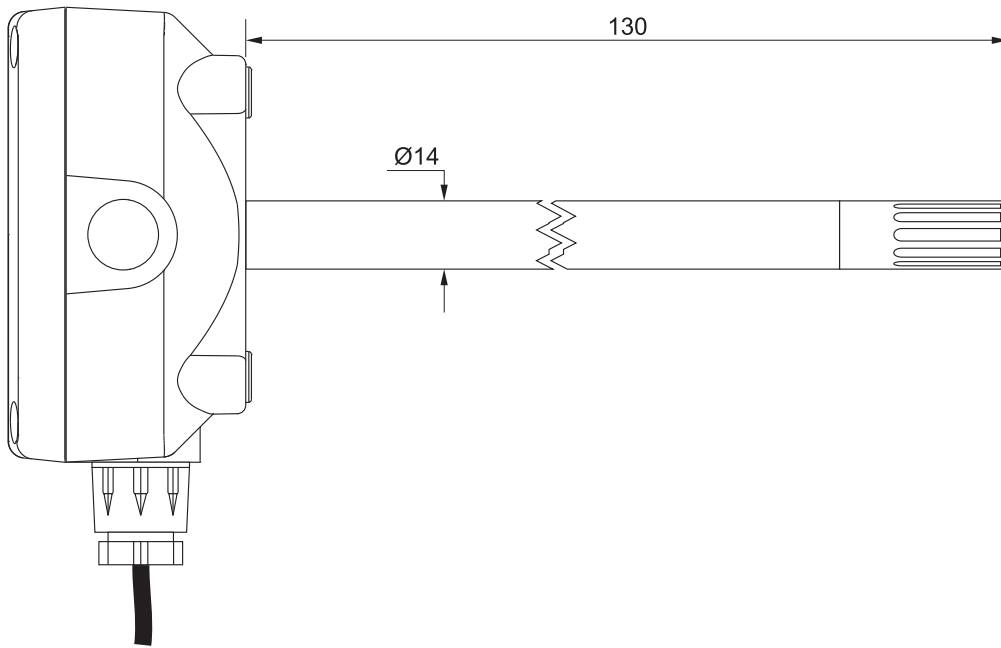

**HVAC40...17TO**

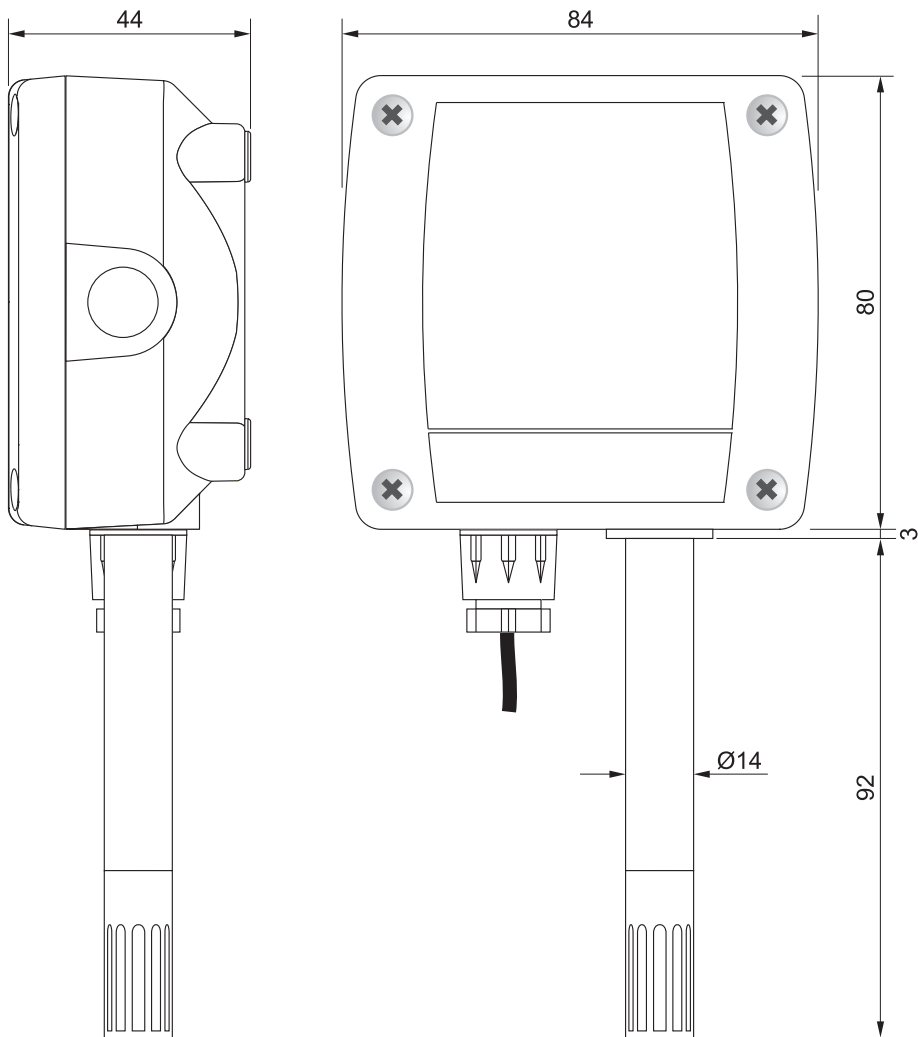

**HVAC40...17TV**

### 3 INSTALLATION

By opening the lid, 3 mm diameter holes are available so to allow securing the base of the instrument directly to a panel or to the wall.

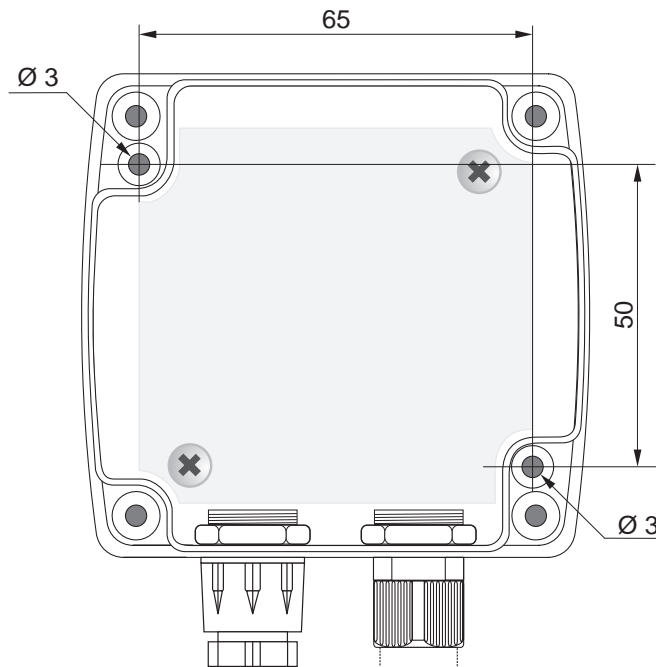

The models with duct horizontal probe can be fixed by using the HD9008.31 flange, a PG16 metal cable gland (Ø 10...14 mm) or a 3/8" universal biconical connection.

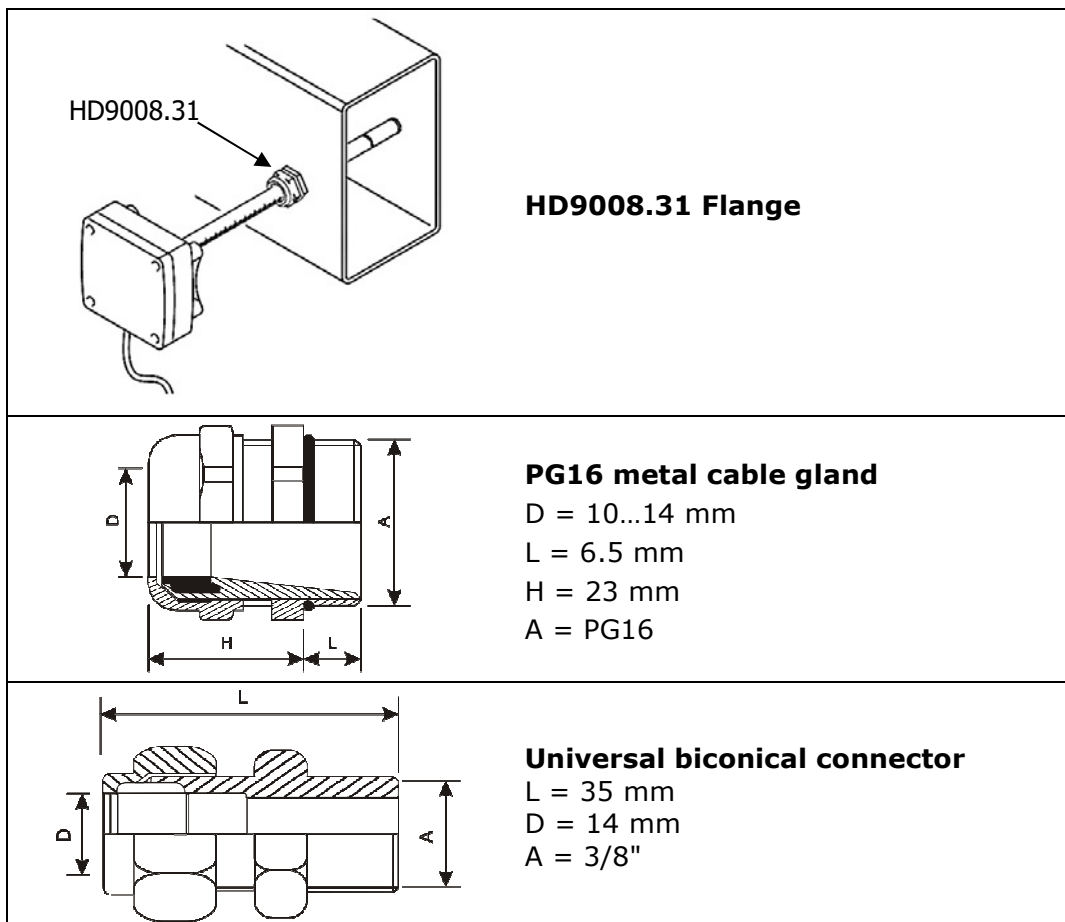

Internally there are:

- the terminal header for connecting the power supply and the output;
- the RS232 serial connector (COM AUX, except HVAC40S17...);
- the dip switches for quick configuration.
- the buttons for the configuration via display (only HVAC40R17...).

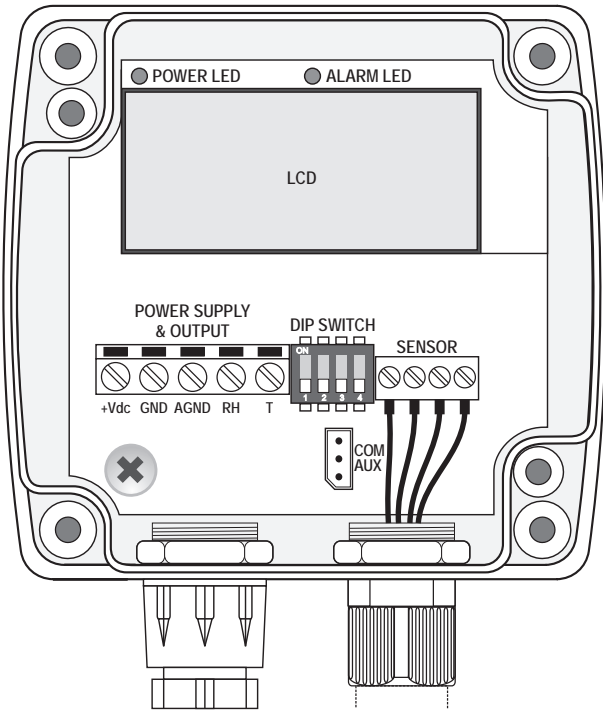

**Models with active analog output  
(HVAC4017... and HVAC40V17...)**

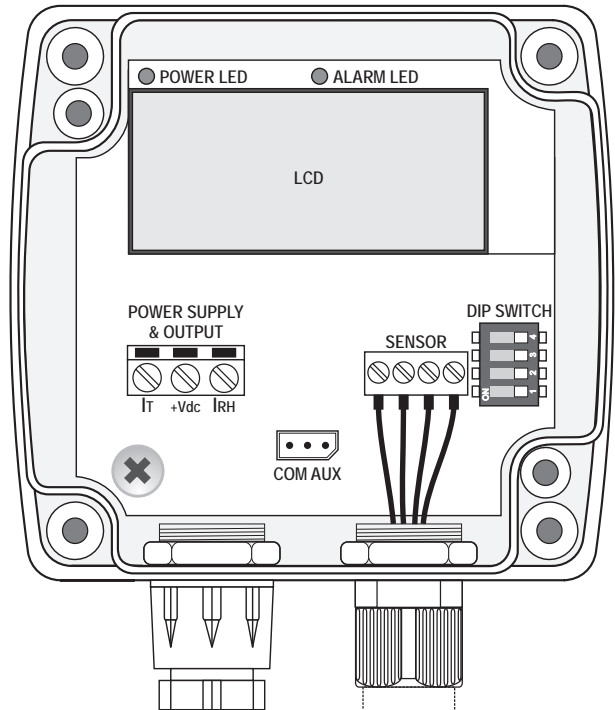

**Models with 2-wire current output  
(HVAC40A17...)**

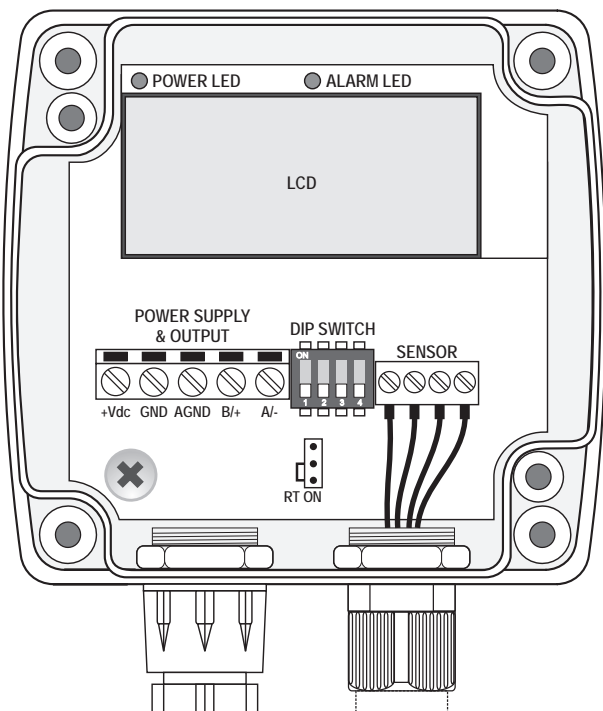

**Models with digital RS485 output  
(HVAC40S17...)**

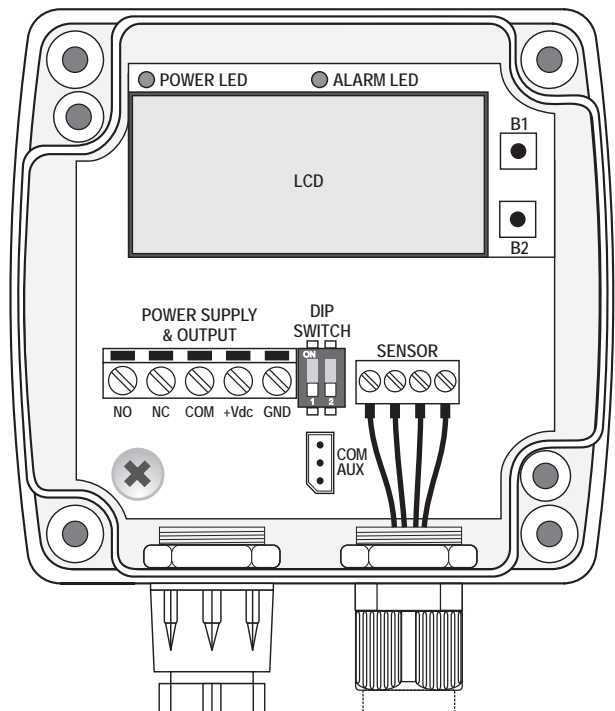

**Models with relay switch output  
(HVAC40R17...)**



### 3.1 ELECTRICAL CONNECTIONS

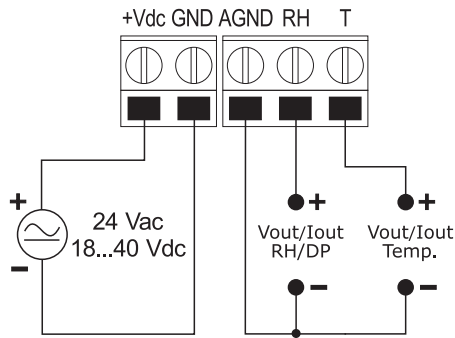

**Models with active analog output (HVAC4017... and HVAC40V17...)**

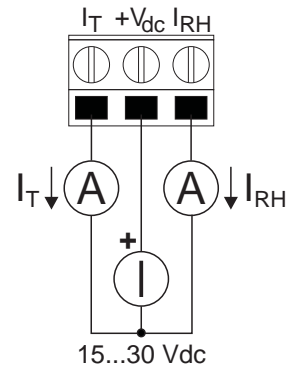

**Models with 2-wire current output (HVAC40A17...)**

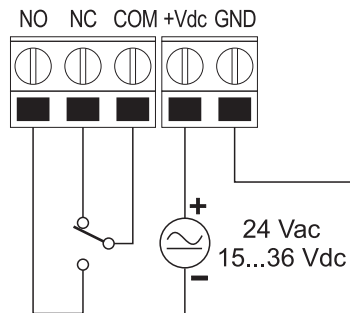

**Models with relay switch output (HVAC40R17...)**

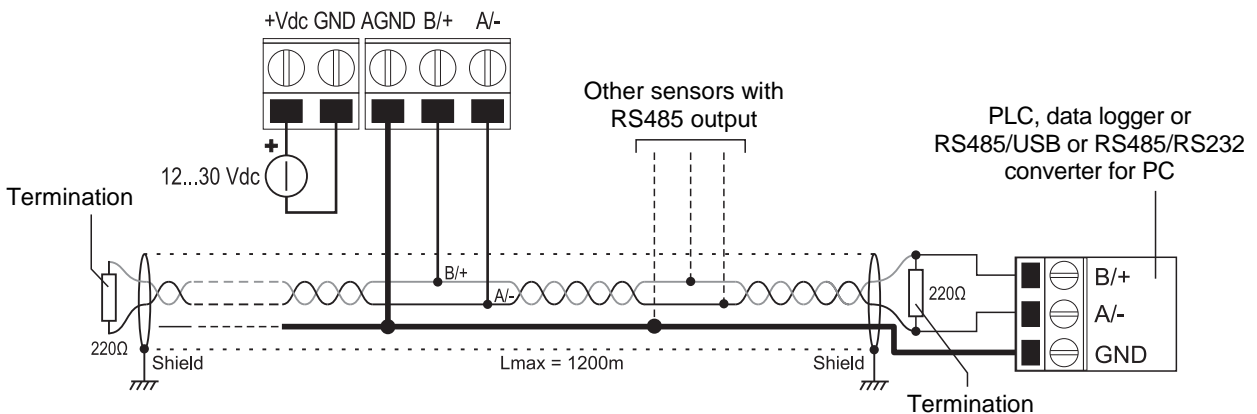

**Models with digital RS485 output (HVAC40S17...)**

In the RS485 connection, the instruments are connected in a sequence through a shielded cable with twisted pair for signals and a third wire for the common. Line termination must be set at the two network ends.

The maximum number of devices that can be connected to the RS485 line (Bus) depends on the load characteristics of the devices to be connected. The RS485 standard requires that the total load does not exceed 32 unit loads. The load of an HVAC40S17T... transmitter is equal to 1/4 of unit load. If the total load is greater than 32 unit loads, divide the network into segments and add a signal repeater between a

segment and the successive one. Line termination should be applied at both ends of each segment.

The instrument has a built-in line termination that can be connected or removed through a short jumper placed at the bottom of the electronic board. If the instrument is the last or the first device of a network group, connect the termination by placing the short jumper on the "RT ON" side. If the instrument is not at the end of a network group, disconnect the termination by placing the short jumper on the side opposite to "RT ON".

The cable shield must be connected to both line ends. The cable should have the following features:

- Characteristic impedance: 120 ohm
- Capacity: less than 50pF/m
- Resistance: less than 100 ohm/km
- Gauge: 0,22 mm<sup>2</sup> (AWG24) at least

The cable maximum length depends on baud rate and cable characteristics. Typically, the maximum length is 1200 m. The data line must be kept separated from any power lines in order to prevent interferences on the transmitted signal.

### **3.2 CONFIGURATION DIP SWITCHES IN THE MODELS WITH ANALOG OUTPUT**

HVAC4017T..., HVAC40A17T... and HVAC40V17T... transmitters have 4 preconfigured temperature ranges for the analog output. In order to use a preconfigured temperature range, set the dip switch 1 to ON and set the temperature range with the dip switches 2 and 3, according to the following table:

Dip switch number			Temperature range
1	2	3	
ON	OFF	ON	0...+50 °C
ON	ON	OFF	-20...+50 °C
ON	OFF	OFF	-20...+80 °C
ON	ON	ON	0...+80 °C
OFF	N.U	N.U	Set via serial

In the HVAC4017T... and HVAC40V17T... models, with active analog output, a dip switch is OFF when placed down; instead, it is ON if placed up. The dip switch 1 is on the left.

In the HVAC40A17T... models, with 2-wire current output, a dip switch is OFF when placed on the right; instead, it is ON if placed on the left. The dip switch 1 is at the bottom.

If a temperature range other than the preconfigured ones is desired, it is necessary to set the dip switch 1 to OFF and set the temperature range via COM AUX serial port.

*Note:* the 4 preconfigured temperature ranges can also be set via COM AUX serial port with the commands K0...K3.

The dip switch 4 is used to select the relative humidity (R.H.) or the dew point (D.P.) measurement.

Dip switch number	Measurement
<b>4</b>	
OFF	R.H.
ON	D.P.

### 3.3 CONFIGURATION DIP SWITCHES IN THE MODELS WITH RS485 DIGITAL OUTPUT

In the HVAC40S17... models, the transmitter Modbus address is equal to the sum of the value set with the dip switches (value settable from 0 to 15) and the value set with the serial command MA (value settable from 1 to 216, default = 1). By setting a dip switch to ON (upwards), the following values are added to the address:

	Dip switch number			
	1	2	3	4
<b>ON</b>	8	4	2	1
<b>OFF</b>	0	0	0	0

Example: if the dip switches 1 and 3 are set to ON and the dip switches 2 and 4 are set to OFF, the value set with the dip switches is  $8+2=10$ . If the value set with the serial command MA is 1 (default value), the transmitter Modbus address is  $10+1=11$ .

The dip switches can be set even if the transmitter is powered, and the change is effective immediately.

**Note:** in the models with RS485 digital output, the selection of the relative humidity or dew point measurement does not take place via a dip switch but via P0/P1 serial commands.

### 3.4 CONFIGURATION DIP SWITCHES IN THE MODELS WITH RELAY OUTPUT

In the HVAC40S17... models, the dip switch 2 is used to select the relative humidity (R.H.) or the dew point (D.P.) measurement.

Dip switch number	Measurement
<b>2</b>	
OFF	R.H.
ON	D.P.

The dip switch 1 is not used.

### 3.5 CONFIGURATION VIA THE SERIAL PORT

- 1) **HVAC4017T..., HVAC40A17T..., HVAC40V17T... and HVAC40R17T... models**  
Connect the COM AUX serial port of the instrument to the RS232 (via the **RS27** cable) or USB (via the cable **CP27**) port of the PC. If the CP27 cable is used, install the USB drivers on your PC.

#### **HVAC40S17T... models**

Connect the RS485 output of the instrument to the RS232 (via a RS485/RS232 converter) or USB (via a RS485/USB converter, for example the **RS48** cable) port of the PC. If a RS485/USB converter is used, install the USB drivers on your PC.

- 2) On the PC, launch a standard serial communication software and set the baud rate to 115200, the communication parameters to 8N2 and the COM port number to which the instrument is connected.
- 3) **Only for HVAC40S17T... models**, power cycle the instrument and send the command @ within 10 seconds from the instrument power on.
- 4) If necessary, send the **CAL START** command. The CAL START command enables the use of some commands, specified in the tables below. The command CAL START is automatically disabled after 5 minutes of inactivity or if the CAL END command or an incorrect command is sent.
- 5) Send the setting or reading commands given below.
- 6) **Only for HVAC40S17T... models**, power cycle the instrument to restore the MODBUS-RTU protocol.

### Serial commands

#### **Instrument general information**

<b>Command</b>	<b>Description</b>
<b>G0</b>	Reads the instrument model If the instrument has analog output, the instrument model is followed by the current output setting (output lower analog value and temperature range associated with the output) Example of reply: HVAC40A17TC.2_4 -20 / 80 °C (output lower analog value = 4 mA, temperature range associated with the output = -20 / 80 °C)
<b>GF</b>	Similar to G0, but provides the configuration of the analog output set via serial
<b>GS</b>	Similar to G0, but provides the configuration of the analog output set via dip switches
<b>G2</b>	Reads the instrument serial number
<b>G3</b>	Reads the instrument firmware version
<b>G4</b>	Reads the instrument firmware date

## Measurement

Command	Description
<b>F0</b>	Disable filtering of measurements (the last instantaneous measurement is provided)
<b>F1</b>	Enable filtering of measurements (default, a weighted average of the last measurements is provided)
<b>P0</b>	Sets relative humidity as humidity measurement (default). <b>Only HVAC40S17...</b>
<b>P1</b>	Sets dew point as humidity measurement. <b>Only HVAC40S17...</b>
<b>GP</b>	Reads the type of measurement set for humidity: relative humidity (0) or dew point (1). <b>Only HVAC40S17...</b>
<b>U3</b>	Displays the temperature measurement on LCD
<b>U4</b>	Displays the humidity measurement on LCD (relative humidity or dew point depending on the setting)
<b>U5</b>	Alternates the temperature and humidity measurements on LCD
<b>UC</b>	Sets °C as temperature unit of measurement (default)
<b>UF</b>	Sets °F as temperature unit of measurement
<b>GU</b>	Reads the temperature unit of measurement
<b>GM</b>	Reads the current measurement (not available in HVAC40S17... models) The measurements are provided without the decimal point and in the sequence temperature, relative humidity and dew point Example of reply: 00230;C; 264;00032;Td C; (23.0 °C; 26.4 %UR; 3.2 °C Td)

## Analog output (only HVAC4017..., HVAC40A17... and HVAC40V17... models)

Command	Description
<b>U0</b>	Sets 0...20 mA as current analog output
<b>U1</b>	Sets 4...20 mA as current analog output (default)
<b>AI</b> snnn	Associates the initial scale of temperature analog output with snnn ("s" is the sign of the value) (*) Default: -200 (= -20.0 °C)
<b>AS</b> snnn	Associates the full scale of temperature analog output with snnn ("s" is the sign of the value) (*) Default: +800 (= +80.0 °C)
<b>AG</b>	Reads the temperature range associated with the analog output Example of reply: User Analog Scale: -200 / +800 C (-20.0...+80.0 °C)
<b>KU</b>	Enables the temperature range set with the AIsnnn and ASsnnn commands
<b>K0</b>	Enables the -20...+80 °C temperature range
<b>K1</b>	Enables the -20...+50 °C temperature range
<b>K2</b>	Enables the 0...+50 °C temperature range
<b>K3</b>	Enables the 0...+80 °C temperature range

(\*) The value must be written without the decimal point, even if it is not an integer value (e.g., to associate 50.0 °C with the full scale of analog output, write AS+500). The value is considered in the unit of measurement set in the instrument.

The temperature range set with the AISnnn and ASsnnn commands is active only if it is enabled with the KU command and the dip switch 1 is set to OFF.

### Alarm (only HVAC40R17... models)

The commands starting with **AW** require prior sending of the **CAL START** command.

The threshold values refer to the relative humidity measurement or the dew point measurement depending on the humidity measurement selected (via P0/P1 serial commands for HVAC40S17... models, via dip switch for the other models).

Command	Description
<b>AWSn</b>	Sets the relay operating mode n=0 ⇒ Negative (NC contact is closed if no alarm, NO contact is closed if in alarm) n=1 ⇒ Positive (NO contact is closed if no alarm, NC contact is closed if in alarm) Default: Negative
<b>ARS</b>	Reads the relay operating mode
<b>AWBn</b>	Sets the buzzer activation status: n=0 ⇒ OFF (default); n=1 ⇒ ON
<b>ARB</b>	Reads the buzzer activation status
<b>AWAn</b>	Sets the alarm activation status: n=0 ⇒ OFF (default); n=1 ⇒ ON
<b>ARA</b>	Reads the alarm activation status
<b>AWE<sub>n</sub></b>	Sets the alarm operating mode n=0 ⇒ Above threshold (alarm is on if measurement is greater than threshold 1) n=1 ⇒ Below threshold (alarm is on if measurement is less than threshold 1) n=2 ⇒ Outside thresholds (alarm is on if measurement is less than threshold 1 or greater than threshold 2) Default: Above threshold
<b>ARE</b>	Reads the alarm operating mode
<b>AWT1snnn</b>	Sets the threshold 1 value to snnn ("s" is the sign of the value) (*) Default: 300 (=30.0 %RH)
<b>ART1</b>	Reads the threshold 1 value
<b>AWT2snnn</b>	Sets the threshold 2 value to snnn ("s" is the sign of the value) (*) Default: 700 (=70.0 %RH)
<b>ART2</b>	Reads the threshold 2 value
<b>AWHnnn</b>	Sets the hysteresis value to nnn (*) Default: 100 (=10.0 %RH)
<b>ARH</b>	Reads the hysteresis value
<b>AWD1nnn</b>	Sets the alarm activation delay to nnn seconds (0... 600 s) Default: 0
<b>ARD1</b>	Reads the alarm activation delay value
<b>AWD2nnn</b>	Sets the alarm deactivation delay to nnn seconds (0... 600 s) Default: 0
<b>ARD2</b>	Reads the alarm deactivation delay value

(\*) The value must be written without the decimal point, even if it is not an integer value (e.g., to set thresholds 1 to 15.0 %RH, write AWT1+150). In the case of the dew point measurement, the thresholds and hysteresis values are considered in the unit of measurement set in the instrument.

## MODBUS (only HVAC40S17... models)

Command	Description
<b>MA</b> nnn	Sets MODBUS address to nnn (default 1)
<b>L1</b>	Reads the MODBUS address
<b>MB</b> n	Sets the MODBUS Baud Rate to: <ul style="list-style-type: none"> <li>▪ 9600 if n=0</li> <li>▪ 19200 if n=1 (default)</li> <li>▪ 38400 if n=2</li> <li>▪ 57600 if n=3</li> <li>▪ 115200 if n=4</li> </ul>
<b>L2</b>	Reads the MODBUS Baud Rate
<b>MP</b> n	Sets MODBUS parity and stop bits to: <ul style="list-style-type: none"> <li>▪ 8N1 if n=0 [No parity, 1 stop bit]</li> <li>▪ 8N2 if n=1 [No parity, 2 stop bits]</li> <li>▪ 8E1 if n=2 [Even parity, 1 stop bit] (default)</li> <li>▪ 8E2 if n=3 [Even parity, 2 stop bits]</li> <li>▪ 8O1 if n=4 [Odd parity, 1 stop bit]</li> <li>▪ 8O2 if n=5 [Odd parity, 2 stop bits]</li> </ul> <p>The number of bits is fixed to 8</p>
<b>L3</b>	Reads the setting of MODBUS parity and stop bits
<b>MW</b> n	Sets waiting time after MODBUS transmission to: <ul style="list-style-type: none"> <li>▪ Immediate reception if n=0 (violates protocol)</li> <li>▪ Waiting 3.5 characters if n=1 (default, respects protocol)</li> </ul>
<b>L4</b>	Reads the setting of waiting time after MODBUS transmission

## Relative humidity calibration

The commands starting with **R** require prior sending of the **CAL START** command.

Command	Description
<b>GC</b>	Reads the calibration type in use: factory or user
<b>GD</b>	Reads the factory calibration date (format yyyy/mm/dd hh.mm.ss)
<b>GE</b>	Reads the user calibration date (format yyyy/mm/dd hh.mm.ss)
<b>R0</b> vv.v	Calibrates the relative humidity lower point to the value vv.v %RH The value must be between 300 (=30.0 %RH) and 350 (=35.0 %RH)
<b>R1</b> vv.v	Calibrates the relative humidity upper point to the value vv.v %RH The value must be between 730 (=73.0 %RH) and 770 (=77.0 %RH)
<b>RU0</b>	Uses the factory calibration
<b>RU1</b>	Uses the user calibration
<b>RR</b>	Resets the user calibration to the factory calibration
<b>RD</b> yymmddhhmmss	Sets the user calibration date

### **3.6 CONFIGURATION VIA THE INTERNAL BUTTONS (ONLY HVAC40R17...)**

---

The upper button **B1** allows scrolling the available operating parameters, while the lower button **B2** allows changing the setting of the selected parameter.

The function of a button depends on whether it is short or long pressed. To short press a button, hold it down for about 1 second, until the power LED turns off. To long press a button, hold it down for at least 3 seconds, until the power LED turns off and then turns on again.

Long press the upper button **B1** to enter the menu. Inside the menu, long press **B1** to scroll the available parameters. Below is the sequence of the operating parameters (in brackets the indication that appears on the display) with the possible settings for non-numerical parameters:

- **Relay operating mode (SECU):**
  - Negative (NEG): NC contact is closed if no alarm, NO contact is closed if in alarm
  - Positive (POS): NO contact is closed if no alarm, NC contact is closed if in alarm
- **Buzzer activation (BEEP):**
  - OFF: buzzer disabled
  - ON: buzzer enabled
- **Alarm activation (ALAR):**
  - OFF: alarm disabled
  - ON: alarm enabled
- **Alarm operating mode (EDGE):**
  - Above threshold (RISE): alarm is on if measurement is greater than threshold 1
  - Below threshold (FALL): alarm is on if measurement is less than threshold 1
  - Outside thresholds (OUTS): alarm is on if measurement is less than threshold 1 or greater than threshold 2
- **Threshold 1 (THR1):** Value of the threshold for above (RISE) and below (FALL) alarm operating modes; value of the lower threshold for outside thresholds (OUTS) alarm operating mode.
- **Threshold 2 (THR2):** Value of the upper threshold for outside thresholds (OUTS) alarm operating mode. The parameter appears only if the alarm operating mode is set to OUTS.
- **Hysteresis (HYST):** Value of the hysteresis for above (RISE) and below (FALL) threshold alarm operating modes. The parameter does appear if the alarm operating mode is set to OUTS.
- **Alarm activation delay (T1):** Value in seconds of the time delay for generating the alarm. The alarm is generated only if the measurement exceeds the threshold for more than the set time.
- **Alarm deactivation delay (T2):** Value in seconds of the time delay for deactivating the alarm. The alarm is deactivated only after the set time has elapsed from the disappearance of the alarm condition.

**Note:** the threshold values refer to the relative humidity measurement or the dew point measurement depending on the humidity measurement selected (via P0/P1 serial commands for HVAC40S17... models, via dip switch for the other models).



**Note:** the EDGE, THR1, THR2, HYST, T1 and T2 parameters do not appear if the alarm is set to OFF.

**Changing non-numerical parameters:**

- Select the parameter by using the button **B1**.
- Short press the button **B2** to change the setting.
- Long press the button **B1** to move to the next parameter.

**Changing numerical parameters:**

- Select the parameter by using the button **B1**.
- Short press the button **B2** to change the sign.
- Long press the button **B2** to select the first digit.
- Short press the button **B2** to change the selected digit.
- Long press the button **B2** to select the next digit.
- Repeat the above two steps until all the digits are set.
- Long press the button **B1** to move to the next parameter.

While a parameter value is displayed, a short press of the button **B1** will briefly show the name of the currently selected parameter.

## 4 ALARM OPERATING MODES (HVAC40R17...)

The operating modes shown are valid only for the HVAC40R17... models.

**Above threshold (RISE):** the alarm is turned on if the measurement is greater than threshold 1 for more than T1 seconds. The alarm is turned off when the measurement becomes less than threshold 1 minus the hysteresis for more than T2 seconds.

The up arrow on the left of the display is shown when this mode is selected.

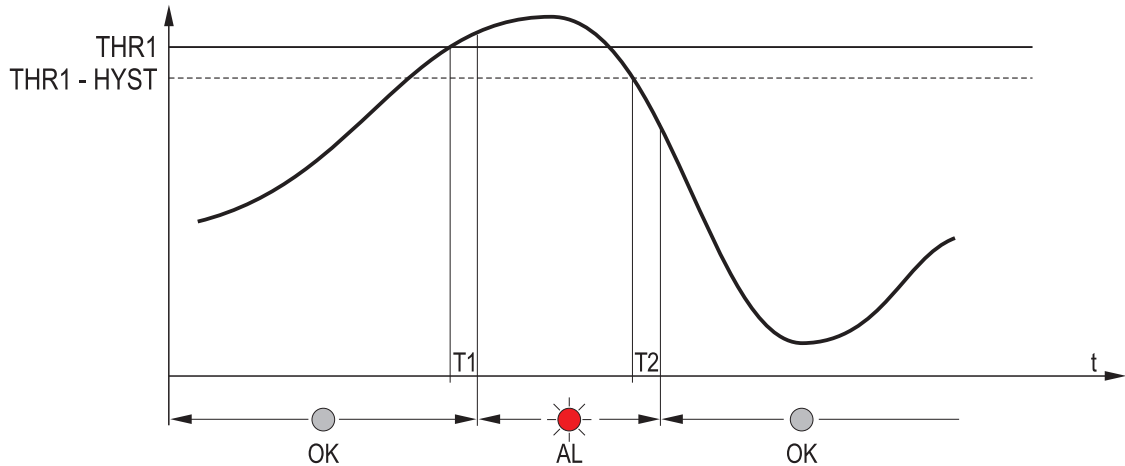

**Below threshold (FALL):** the alarm is turned on if the measurement is less than threshold 1 for more than T1 seconds. The alarm is turned off when the measurement becomes greater than threshold 1 plus the hysteresis for more than T2 seconds.

The down arrow on the left of the display is shown when this mode is selected.

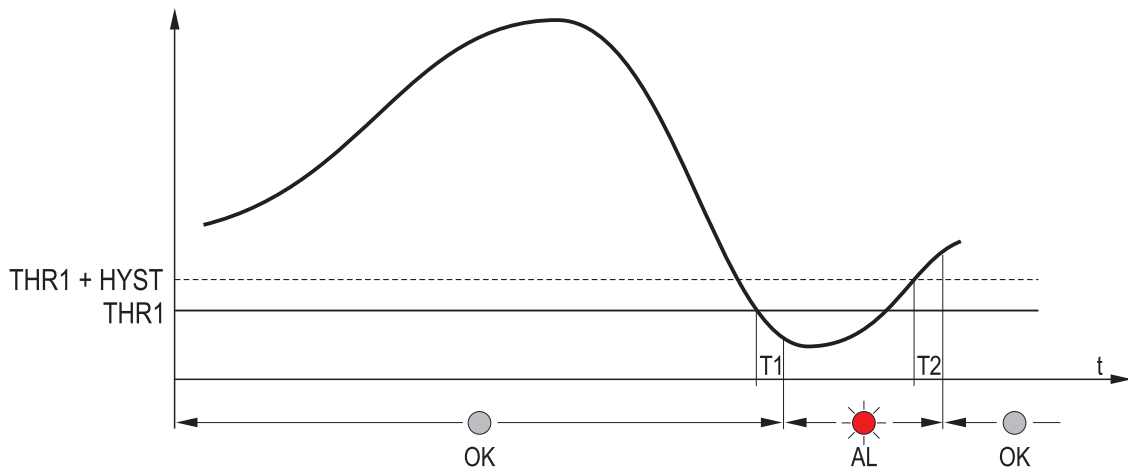

**Outside thresholds (OUTS):** the alarm is turned on if the measurement is greater than threshold 2 or less than threshold 1 for more than T1 seconds. The alarm is turned off when the measurement returns between the two thresholds for more than T2 seconds. No hysteresis is applied to the thresholds.

The up and down arrows on the left of the display are shown when this mode is selected.

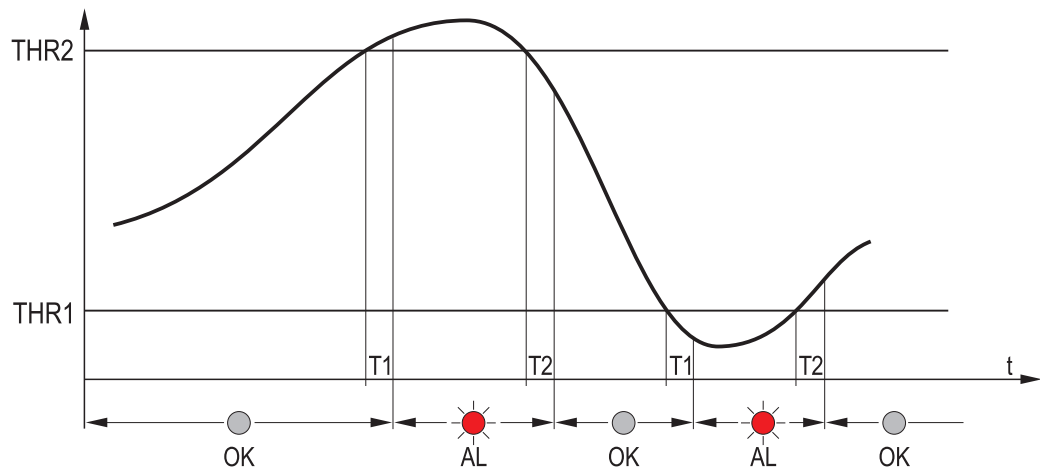

When the measurement is in alarm, the red LED lights up, the buzzer is on (if enabled) and the relay is switched (depending on the chosen relay operating mode).

While in alarm, the buzzer can be stopped (only for the current event) by short pressing the button B1.

The alarm is disabled while in the configuration menu.

## 5 MODBUS-RTU (HVAC40S17...)

The default communication parameters are 19200, 8E1 and can be changed with the serial commands MB/MP.

The instrument address (default 1) can be changed with the serial command MA.

The MODBUS registers available are shown below.

### Input Registers

Register number	Register address	Datum	Format
1	0	Temperature in °C (x10)	16-bit integer
2	1	Temperature in °F (x10)	16-bit integer
3	2	Relative Humidity in % (x10)	16-bit integer
4	3	Dew Point in °C (x10)	16-bit integer
5	4	Dew Point in °F (x10)	16-bit integer
6	5	Status register Bit 0 = 1 ⇒ temperature measurement error Bit 1 = 1 ⇒ relative humidity measurement error Bit 2 = 1 ⇒ dew point measurement error Bit 3 = 1 ⇒ configuration data error	16-bit integer

## 6 INSTRUMENT STORAGE

Instrument storage conditions:

- Temperature: -20...+80 °C.
- Humidity: less than 90 %RH no condensation.
- In storage, avoid places where:
  - humidity is high;
  - the instrument is exposed to direct sun radiation;
  - the instrument is exposed to a high temperature source;
  - high vibration levels are present;
  - the instrument may be exposed to vapor, salt and/or corrosive gas.

## 7 SAFETY INSTRUCTIONS

### General safety instructions

The instrument has been manufactured and tested in accordance with the safety standard EN61010-1:2010 "Safety requirements for electrical equipment for measurement, control and laboratory use" and has left the factory in perfect safety technical conditions.

The instrument proper operation and operating safety can be ensured only if all standard safety measures as well as the specific measures described in this manual are followed.

The instrument proper operation and operating safety can be ensured only in the climatic conditions specified in this manual.

Do not use the instruments in places where there are:

- Corrosive or flammable gases.
- Direct vibrations or shocks to the instrument.
- High-intensity electromagnetic fields, static electricity.

### User obligations

The instrument operator shall follow the directives and regulations below that refer to the treatment of dangerous materials:

- EEC directives on workplace safety.
- National law regulations on workplace safety.
- Accident prevention regulations.

## 8 ACCESSORIES ORDERING CODES

- RS27** RS232 null-modem serial connection cable with SubD 9-pin connector on the PC side and 3-pole connector on the side of the instrument.
- CP27** Serial connection cable with USB connector on the PC side and 3-pole connector on the side of the instrument. The cable has a built-in USB/RS232 converter and it connects the instrument directly to the USB port of the PC.
- RS48** Cable for RS485 connection with built-in USB/RS485 converter. The cable has USB connector for PC and 3 separate wires for the instruments.
- HD33** 33%RH saturated solution for checking the relative humidity sensor, complete with screw adaptor for probes Ø14 mm, M12×1 thread.
- HD75** 75%RH saturated solution for checking the relative humidity sensor, complete with screw adaptor for probes Ø14 mm, M12×1 thread.
- HD9008.31** Wall flange with cable gland to fix Ø 14 mm probes.
- PG16** AISI304 cable gland for Ø 14 mm probes.

**DELTA OHM metrology laboratories LAT N° 124 are ISO/IEC 17025 accredited by ACCREDIA for Temperature, Humidity, Pressure, Photometry / Radiometry, Acoustics and Air Velocity. They can supply calibration certificates for the accredited quantities.**

**DICHIARAZIONE DI CONFORMITÀ UE  
EU DECLARATION OF CONFORMITY****Delta Ohm S.r.L. a socio unico – Via Marconi 5 – 35030 Caselle di Selvazzano – Padova – ITALY**Documento Nr. / Mese.Anno: **5148 / 02.2020**  
Document-No. / Month.Year :

Si dichiara con la presente, in qualità di produttore e sotto la propria responsabilità esclusiva, che i seguenti prodotti sono conformi ai requisiti di protezione definiti nelle direttive del Consiglio Europeo:  
*We declare as manufacturer herewith under our sole responsibility that the following products are in compliance with the protection requirements defined in the European Council directives:*

Codice prodotto: **HVAC4017T... / HVAC40A17T... / HVAC40V17T...**  
Product identifier : **HVAC40R17T... / HVAC40S17T...**Descrizione prodotto: **Trasmettitori di temperatura e umidità / Igrostatì**  
Product description : **Temperature and humidity transmitters / Hygrostats**I prodotti sono conformi alle seguenti Direttive Europee:  
*The products conform to following European Directives:*

Direttive / Directives	
2014/30/EU	Direttiva EMC / EMC Directive
2014/35/EU	Direttiva bassa tensione / Low Voltage Directive
2011/65/EU - 2015/863/EU	RoHS / RoHS

Norme armonizzate applicate o riferimento a specifiche tecniche:  
*Applied harmonized standards or mentioned technical specifications:*

Norme armonizzate / Harmonized standards	
EN 61010-1:2010	Requisiti di sicurezza elettrica / Electrical safety requirements
EN 61326-1:2013	Requisiti EMC / EMC requirements
EN 50581:2012	RoHS / RoHS

Il produttore è responsabile per la dichiarazione rilasciata da:  
*The manufacturer is responsible for the declaration released by:*

Johannes Overhues

Amministratore delegato  
Chief Executive Officer

Caselle di Selvazzano, 24/02/2020

Questa dichiarazione certifica l'accordo con la legislazione armonizzata menzionata, non costituisce tuttavia garanzia delle caratteristiche.

*This declaration certifies the agreement with the harmonization legislation mentioned, contained however no warranty of characteristics.*

## WARRANTY

Delta OHM is required to respond to the "factory warranty" only in those cases provided by Legislative Decree 6 September 2005 - n. 206. Each instrument is sold after rigorous inspections; if any manufacturing defect is found, it is necessary to contact the distributor where the instrument was purchased from. During the warranty period (24 months from the date of invoice) any manufacturing defects found will be repaired free of charge. Misuse, wear, neglect, lack or inefficient maintenance as well as theft and damage during transport are excluded. Warranty does not apply if changes, tampering or unauthorized repairs are made on the product. Solutions, probes, electrodes and microphones are not guaranteed as the improper use, even for a few minutes, may cause irreparable damages.

Delta OHM repairs the products that show defects of construction in accordance with the terms and conditions of warranty included in the manual of the product. For any dispute, the competent court is the Court of Padua. The Italian law and the "Convention on Contracts for the International Sales of Goods" apply.

## TECHNICAL INFORMATION

The quality level of our instruments is the result of the continuous product development. This may lead to differences between the information reported in the manual and the instrument you have purchased. In case of discrepancies and/or inconsistencies, please write to sales@deltaohm.com. Delta OHM reserves the right to change technical specifications and dimensions to fit the product requirements without prior notice.

## DISPOSAL INFORMATION

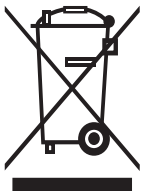

Electrical and electronic equipment marked with specific symbol in compliance with 2012/19/EU Directive must be disposed of separately from household waste. European users can hand them over to the dealer or to the manufacturer when purchasing a new electrical and electronic equipment, or to a WEEE collection point designated by local authorities. Illegal disposal is punished by law.

Disposing of electrical and electronic equipment separately from normal waste helps to preserve natural resources and allows materials to be recycled in an environmentally friendly way without risks to human health.



**V1.2**  
**07/2021**